



**STRONG PARTNERS.
TOUGH TRUCKS.™**



HYSTER UT SERIES

ELECTRIC WALKIE PALLET TRUCK

P1.5UT / 1500KG

HYSTER.COM.AU

> OVERVIEW

P1.5UT

THE HYSTER® ELECTRIC WALKIE PALLET TRUCK P1.5UT COMBINES ERGONOMIC FEATURES AND RELIABLE PERFORMANCE WITH ENERGY EFFICIENT TECHNOLOGY. LOW MAINTENANCE DELIVERS INCREASED PRODUCTIVITY AND REDUCED OPERATIONAL COSTS.

Productivity

- Small turning radius (1454 mm)
- Performs well on gradients
- Long handle reduces steering effort
- Drive capability when tiller is upright, greatly reduces turning space
- Entry roller for easy operation
- Variable speed control
- Built in charger
- Low speed switch in the handle
- Floating balance wheel automatically adjusts height and improves stability when unloading

Safety Features

- Emergency stop button
- Emergency reversing belly button
- Casters to increase stability

Optimum Structural Design

- Formed heavy gauge steel provides maximum fork strength and longevity
- Pull rod design protects against bending
- Durable plastic covers
- Compact and lightweight design

Serviceability

- Fast and efficient servicing
- Simple components
- Computer-based diagnostics not required
- Sealed maintenance free batteries
- Tandem wheel option available



**Handle (Standard)
(Left and Right Handed)**



**Entry roller for
easy operation**

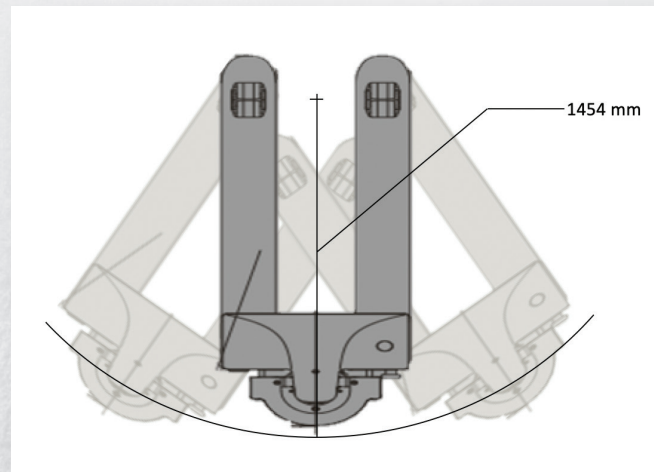

Small turning radius

SPECIFICATIONS AND DIMENSIONS

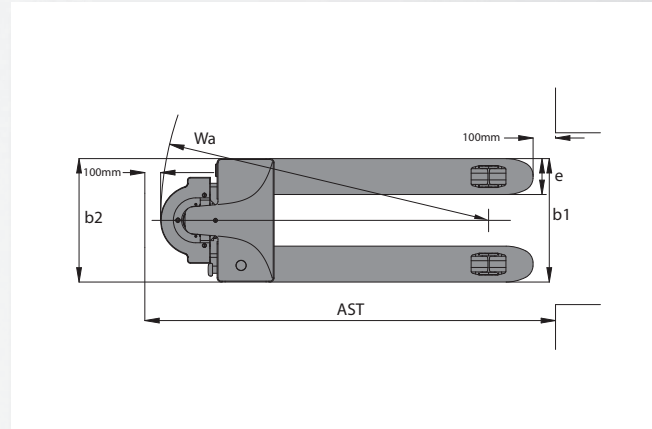
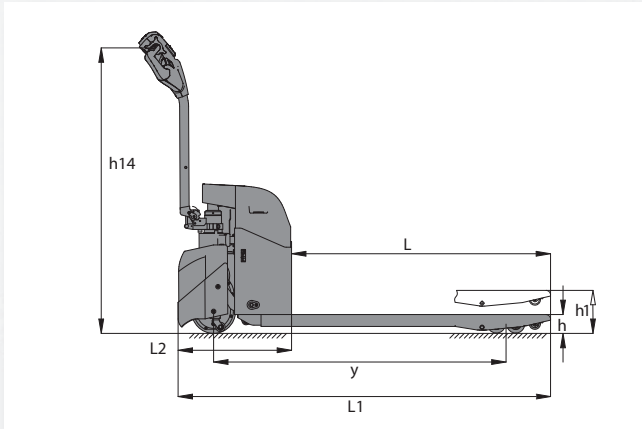

MODEL	MEASUREMENT	P1.5UT
Power Type		24-volt
Operator Type		Pedestrian
Rated Capacity	kg	1500
Load Center	mm	600
Fork Length	L (mm)	1150
Fork Overall Width	b1 (mm)	685 / 520
Fork Width (Individual Fork)	e (mm)	160
Wheelbase (Raised / Lowered)	y (mm)	1287 / 1357
Overall Length	L1 (mm)	1654
Outside Turning Radius (Raised)	Wa (mm)	1454
Right Angle Stack (1000 x 1200 Crossways)	AST (mm)	1854
Overall Lift Height – Top of Forks	h1 (mm)	190
Lowered Height – Top of Forks	h (mm)	75
Total Lift	mm	115
Truck Overall Width	b2 (mm)	685 / 562
Chassis Length	L2 (mm)	504
Height of Tiller (max.)	h14 (mm)	1270
Battery Compartment – Standard	mm	228 / 138 / 214
Maximum Gradeability (Loaded / Unloaded)	%	5% / 10%
Maximum Travel Speed (Loaded / Unloaded)	kph	4.3 / 4.8
Traction Motor Control Method Type		DC
Service Brake Type		Electric
Truck Weight (approximate) with battery - NL / RL	kg	205 / 1705
Drive Tyre – Size / Type (Number of Wheels)	mm	φ195 x 70 Poly (1)
Load Wheel – Size / Type (Number of Wheels)	mm	φ74 x 90 Poly Single / φ74 x 70 Poly Tandem
Battery Type		Sealed
Battery Ampere Hours	Ah	65
Battery Weight	kg	36
On Board Charger	V	100-240

P1.5UT Power Plug Type



HYSTER® DEALERS



Contact your nearest Hyster® Dealership
by visiting www.hyster.com.au

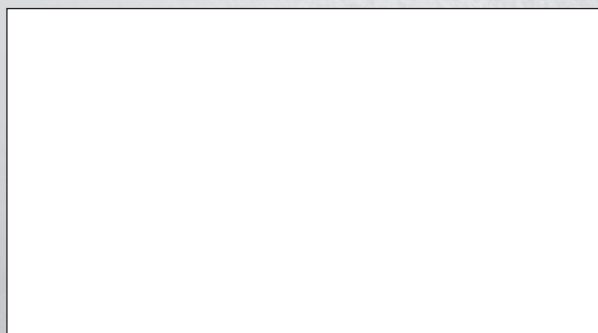

HYSTER PACIFIC

1 Bullecourt Avenue, Milperra NSW, Australia 2214
Tel: +61 (2) 9795 3800 Fax: +61 (2) 9792 8484

HYSTER ASIA

16 Tuas Avenue 20, Singapore 638827
Tel: +65 68633387 Fax: +65 68633349
hyster.com/pacific/en-au
hyster.com/asia/en-sg



/Hysterasiapacific



HysterJAPIC



Hyster Asia-Pacific