



**STRONG PARTNERS.  
TOUGH TRUCKS.™**



# **HYSTER UT SERIES**

**ELECTRIC RIDER PALLET TRUCK**

**P2.OUTS / 2000KG**

**[HYSTER.COM.AU](http://HYSTER.COM.AU)**

## > OVERVIEW

# P2.OUTS

**THE HYSTER® ELECTRIC RIDER PALLET TRUCK P2.OUTS DELIVERS A LOW COST OF OPERATION. THESE ROBUST PLATFORM PALLET TRUCKS CAN OPTIMISE VEHICLE LOADING AND UNLOADING OPERATIONS, AS WELL AS BOOSTING PALLET TRANSPORTATION RATES OVER SHORT AND LONG DISTANCES.**

### Productivity

- Advanced AC control system eliminates the motor brushes, which limits maintenance requirements
- Low skirtings on main chassis
- The side battery roll-out system is very convenient to replace batteries
- Built-in pressure relief valve protects the trucks from overloading
- Emergency power disconnect switch
- Long handle reduces steering effort
- Emergency reversing system in handle
- Low speed switch in the handle
- Variable speed control
- Cold store configuration (option)

### Optimum Structural Design

- Spring-loaded casters improve lateral stability on uneven floors and enhance truck performance and service life
- Formed heavy gauge steel provides maximum fork strength and longevity
- Pull rod design protects against bending
- Durable plastic covers

### Serviceability

- CANbus technology reduces wiring complexity
- Low battery protection setting extends the battery life
- All pivot points have grease fittings and serviceable bushing, reducing component wear



**Handle (Standard)  
(Left & Right Handed)**



**Entry Roller for  
Easy Operation**



**One Sided (Cold Store)**



**Two Sided (Cold Store)**

# SPECIFICATIONS AND DIMENSIONS

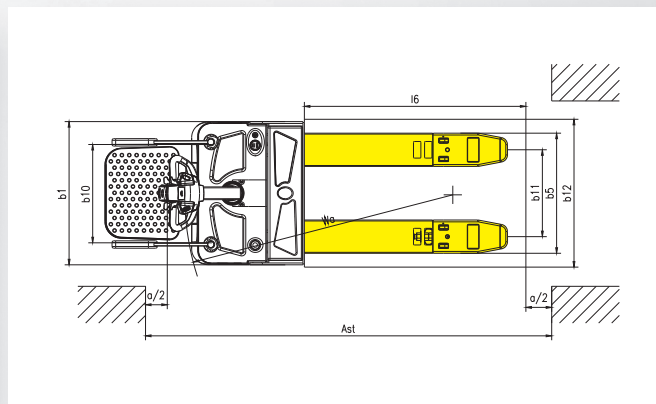
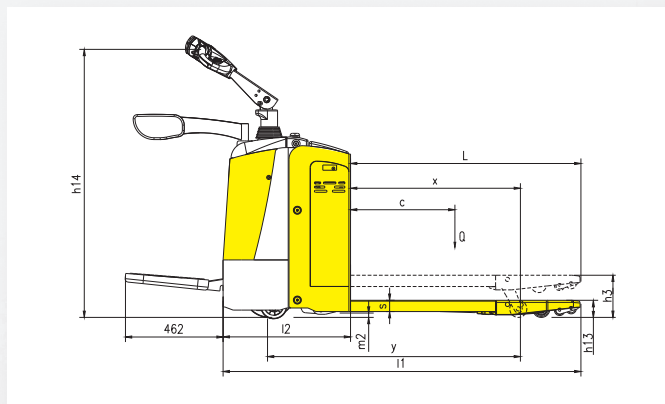

MODEL	MEASUREMENT	P2.0UTS
Load capacity	Q (kg)	2000
Load centre distance	c (mm)	600
Load distance, centre of drive axle to fork	x (mm)	815/865/935
Wheelbase	y (mm)	1261
Fork height, lowered	h13 (mm)	82
Tyre size, front	mm	Φ250×70
Tyre size, rear	mm	Φ82×126 (98)
Additional wheels (dimensions)	mm	Φ127×57
Wheels, number front rear (x=driven wheels)		1x+2/2 (4)
Max.lift height	h3 (mm)	202
Height of tiller in drive position min./max.	h14 (mm)	1150/1430
Overall length	l1 (mm)	1710/1760/1830
Length to face of forks	l1 (mm)	610
Overall width	b1 (mm)	775
Fork dimensions	s/e/l (mm)	53×180×1100 (1150/1220)
Width overall forks	b5 (mm)	550/685
Aisle width for pallets 1000×1200 crossways	Ast (mm)	1910/1960/2030
Aisle width for pallets 800×1200 crossways	Ast (mm)	2010/2010/2030
Turning radius	Wa (mm)	1550/1600/1670
Drive motor power	kW	1.2
Lift motor power	kW	0.8
Sound level at the driver's ear according to DIN12503	dB (A)	70
Travel speed, laden/unladen	Km/h	7/7.1
Battery voltage, nominal capacity K5	V/Ah	24/210
Battery weight	kg	196
Battery dimensions l/w/h	mm	750×170×534
Service weight (with battery)	kg	720

## P2.0UTS Power Plug Type

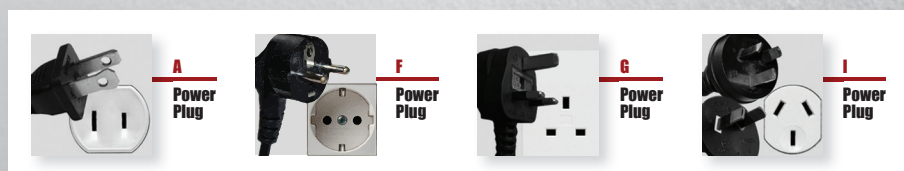

# HYSTER® DEALERS



Contact your nearest Hyster® Dealership  
by visiting [www.hyster.com.au](http://www.hyster.com.au)

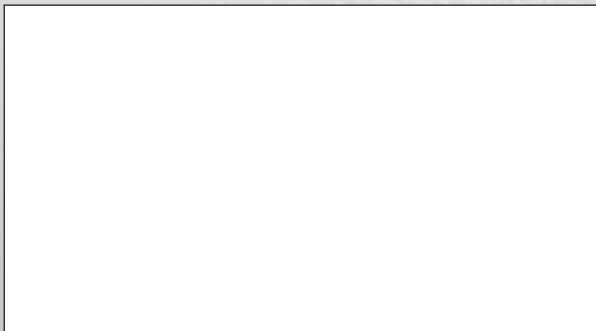

## HYSTER PACIFIC

1 Bullecourt Avenue, Milperra NSW, Australia 2214  
Tel: +61 (2) 9795 3800 Fax: +61 (2) 9792 8484  
[hyster.com/pacific/en-au](http://hyster.com/pacific/en-au)

## HYSTER ASIA

16 Tuas Avenue 20, Singapore 638827  
Tel: +65 6863 3387 Fax: +65 6863 3349  
[hyster.com/asia/en-sg](http://hyster.com/asia/en-sg)



/Hysterasiapacific



HysterJAPIC



Hyster Asia-Pacific