



**STRONG PARTNERS  
TOUGH TRUCKS.™**



# **P1.6UT TECHNICAL GUIDE**

**[WWW.HYSTER.COM](http://WWW.HYSTER.COM)**

# > TRUCK DIMENSIONS

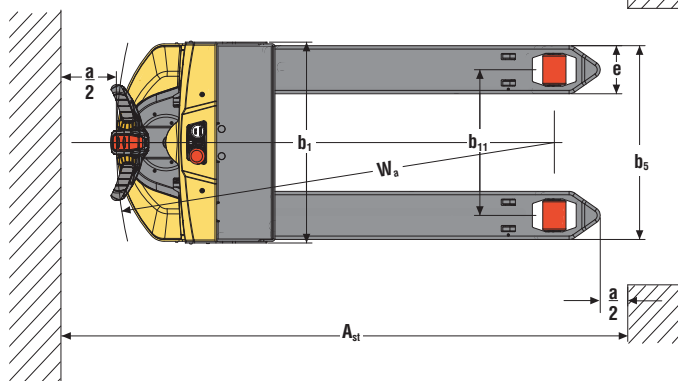
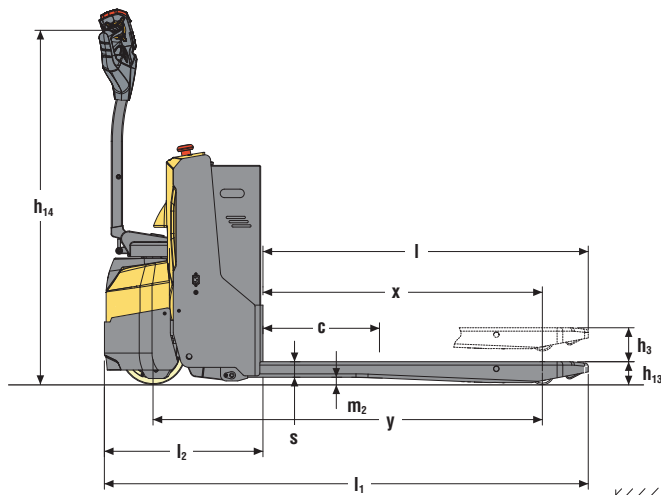
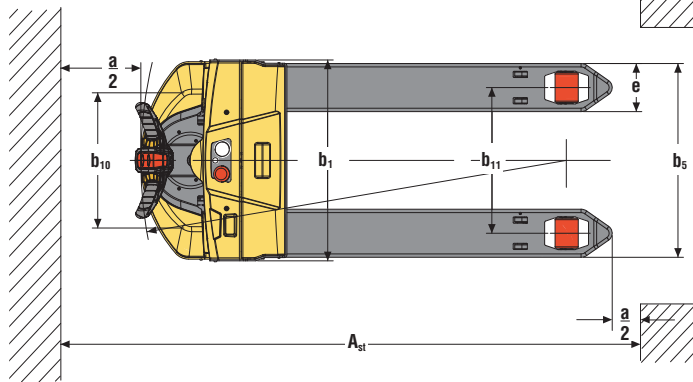
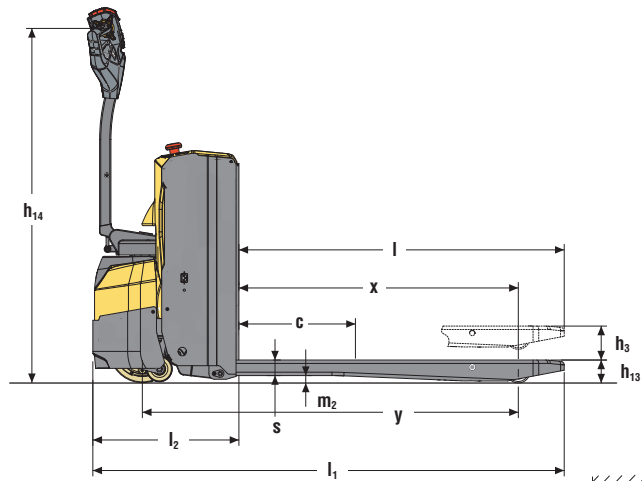

# P1.6UT SPECIFICATIONS



DISTINGUISHING MARK	1.1	Manufacturer (abbreviation)			Hyster	
	1.2	Manufacturer's type designation			P1.6UT	
	1.3	Drive: electric (battery or mains), diesel, petrol, fuel gas			Battery	
	1.4	Operator type: hand, pedestrian, standing, seated, order-picker			Pedestrian	
	1.5	Rated capacity/Rated load	Q	t	1.6	
	1.6	Load centre distance	c	mm	600	
	1.8	Load distance, centre of drive axle to fork	x	mm	984	
	1.9	Wheelbase	y	mm	1330	
	WEIGHT	2.1	Service weight		kg	424
2.2		Axle loading, laden front/rear		kg	2020	
2.3		Axle loading, unladen front/rear		kg	324 / 96	
WHEELS	3.1	Tyres: polyurethane, tophane, NDIthane, front/rear			Polyurethane	
	3.2	Tyre size, front		mm	230 x 100	
	3.3	Tyre size, rear		mm	78 x 98	
	3.4	Additional wheels (dimensions)		mm	90 x 40	
	3.5	Wheels, number front/rear (x = driven wheels)			1x + 2 / 2	
	3.6	Tread, front	b10	mm	480	
	3.7	Tread, rear	b11	mm	375 / 515	
DIMENSIONS	4.4	Lift	h3	mm	120	
	4.9	Height of tiller arm in driving position min./max..	h14	mm	750 / 1250	
	4.15	Height, lowered	h13	mm	78	
	4.19	Overall length	l1	mm	1666	
	4.20	Length to face of forks	l2	mm	514	
	4.21	Overall width	b1 / b2	mm	710	
	4.22	Fork dimensions	s / e / l	mm	55 / 160 / 1150	
	4.25	Outside Fork Width	b5	mm	545	
	4.32	Ground clearance, centre of wheelbase	m2	mm	27	
	4.33	Load dimension b 12 x 16 crossways	b12 x l6	mm	-	
	4.34.1	Aisle width for pallets 1000mm x 1200mm crossways	Ast	mm	2288	
	4.34.2	Aisle width for pallets 800mm x 1200mm lengthwise	Ast	mm	2156	
	4.35	Turning radius	Wa	mm	1488	
	PERFORMANCE	5.1	Travel speed, laden/unladen		km/h	5.8 / 6.0
		5.2	Lift speed, laden/unladen		m/s	0.03 / 0.038
5.3		Lowering speed, laden/unladen		m/s	0.04 / 0.036	
5.7		Gradeability, laden/unladen		%	8 / 20	
5.8		Max. gradeability, laden/unladen		%	-	
5.10		Service brake				Generative
ELECTRIC ENGINE	6.1	Drive motor S2 60 minute rating		kW	1.20	
	6.2	Lift motor, S3 15% rating		kW	0.8	
	6.3	Battery according to DIN 43531/35/36 A,B,C, no				No
	6.4	Battery voltage/nominal capacity K5		V / Ah		24 / 150
	6.5	Battery weight		kg		150
	6.6	Energy consumption according to VDI cycle		kWh/h at no. of cycles		0.25
	6.7	Turnover output		t/h		-
	6.8	Energy consumption at turnover output		kWh in 1 h (kWh/h)		-
8.1	Type of drive unit				AC	
10.7	Sound pressure level at the driver's seat			dB (A)	65	



# STRONG PARTNERS. TOUGH TRUCKS.™

## FOR DEMANDING OPERATIONS, EVERYWHERE.

The Hyster P1.6UT Powered Pallet Truck combines ergonomic features with reliable performance and energy efficient technology. Low maintenance schedules helps increase productivity and reduce operational costs.

### PRODUCTIVITY

- Advanced AC control system eliminates the motor brushes, which limits maintenance requirements
- Side battery roll out system minimises time and effort to replace battery
- Integral pressure relief valve protects from overloading
- Emergency power disconnect switch
- Long tiller arm
- Emergency reversing system in handle
- Low speed switch in the handle
- Variable speed control
- Low energy consumption maximizes battery shift life.

### OPTIMUM STRUCTURAL DESIGN

- Casters improve lateral stability on uneven floors and enhance truck performance and service life
- Formed heavy gauge steel provides maximum fork strength and longevity
- Pull-rod design protects against bending
- Durable plastic covers.

### SERVICEABILITY

- CAN bus technology reduces wiring complexity
- Low battery protection setting extends the battery life
- All pivot points have grease fittings and serviceable bushing, reducing component wear.



**Handle (standard)**  
Left and right handed



**Entry roller for easy operation**

#### NOTICE:

Care must be exercised when handling elevated loads.

Operators must be trained and must read, understand and follow the instructions contained in the Operating Manual.

All values are nominal values and they are subject to tolerances.

For further information, please contact the manufacturer.

Hyster products are subject to change without notice.

Lift trucks illustrated may feature optional equipment.

Values may vary with alternative configurations.



**Safety:** This truck conforms to the current EU requirements.

Specification data is based on VDI 2198.



## HYSTER EUROPE

Centennial House, Frimley Business Park, Frimley, Surrey, GU16 7SG, England.

Tel: +44 (0) 1276 538500



[www.hyster.eu](http://www.hyster.eu)



[infoeurope@hyster.com](mailto:infoeurope@hyster.com)



[/HysterEurope](https://www.facebook.com/HysterEurope)



[@HysterEurope](https://twitter.com/HysterEurope)





[/HysterEurope](https://www.youtube.com/HysterEurope)



HYSTER-YALE UK LIMITED trading as Hyster Europe. Registered Address: Centennial House, Building 4.5, Frimley Business Park, Frimley, Surrey GU16 7SG, United Kingdom.

Registered in England and Wales. Company Registration Number: 02636775.

©2021 HYSTER-YALE UK LIMITED, all rights reserved. HYSTER, , STRONG PARTNERS. TOUGH TRUCKS., MONOTROL and  are trademarks of HYSTER-YALE Group, Inc. .

Hyster products are subject to change without notice. Forklift trucks illustrated may feature optional equipment.