

E80-120XN SERIES



**4-WHEEL ELECTRIC
FORKLIFT TRUCK CUSHION TIRE**
PRODUCT TECHNICAL GUIDE



E80-120XN DIMENSIONS

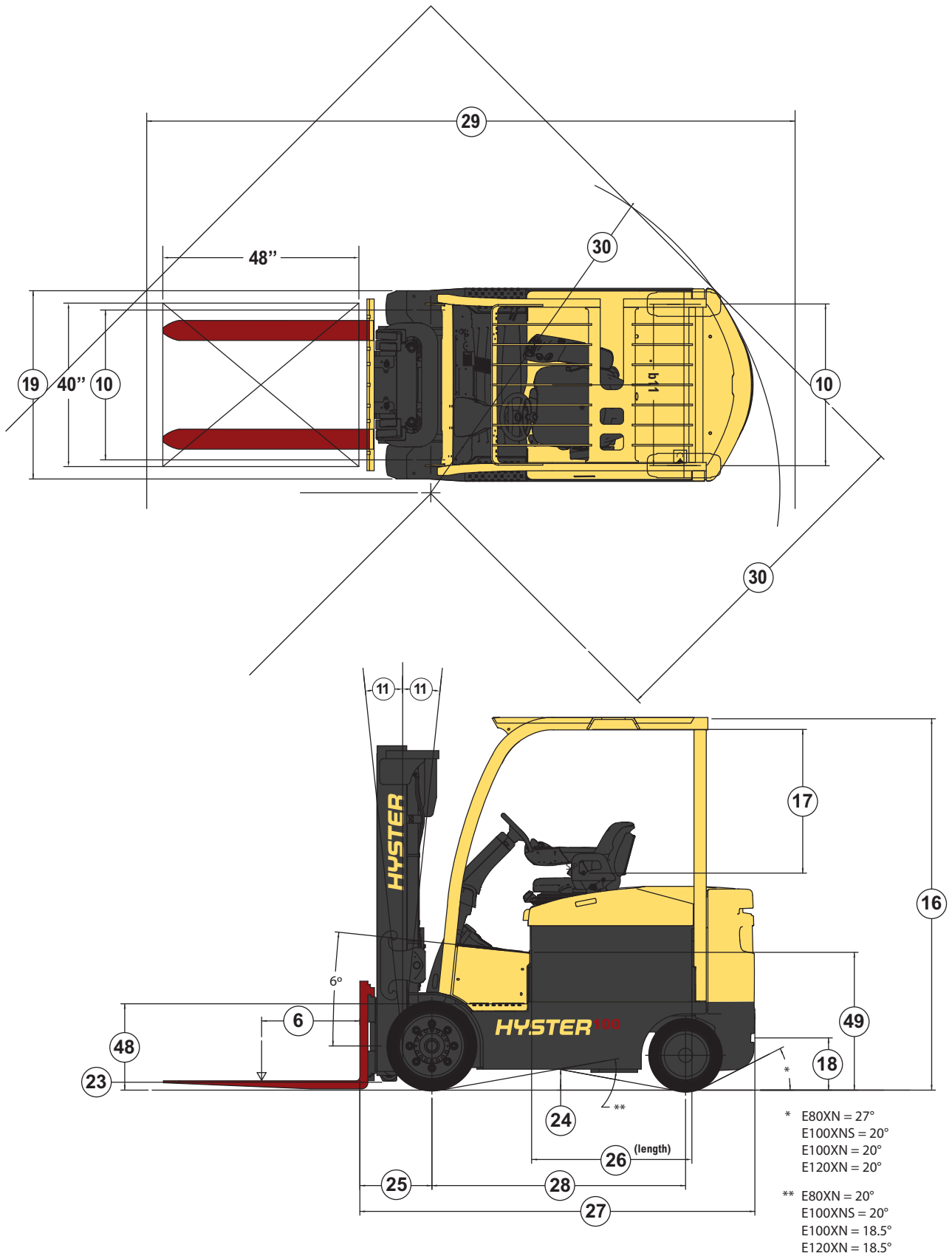

Circled dimensions correspond to the line numbers on the tabulated chart inside the technical guide. Dimensions are in inches (millimeters).

E80XN SPECIFICATIONS

GENERAL	1	Manufacturer			Hyster		
	2	Model designation			E80XN		
	3	Power			Electric		
	4	Operation			Sit		
	5	Rated capacity			lb (kg) 8000 (3629)		
	6	Load center			in (mm) 24 (610)		
TIRES/ WHEELS	7	Tire type - cushion, solid, pneumatic, etc.			Drive/steer Cushion/cushion		
	8	Tire size			Drive/steer in 22 x 9 x 16 / 18 x 6 x 12.1		
	9	Wheels - number	X=driven	Drive/steer	2x/2		
	10	Tread	Center of tires	Narr dr/wide dr/steer	in (mm) 37/41/39.5 (941/1041/1003)		
	11	Mast tilt			Std opt degrees 5F/5B 8F/5B		
	12	Mast - lowered height			Std mast in (mm) 84.1 (2134)		
DIMENSIONS	13	Free lift - top of fork	Std 2-stg limited free lift mast		in (mm) 5 (150)		
			Opt 2-stg full free lift mast with/without LBR		in (mm) 35/53 (900/1352)		
	14	Lift height - top of fork	Std 2-stg limited free lift mast		in (mm) 120 (3050)		
	15	Mast - extended height	Std mast with/without LBR		in (mm) 169/149 (4284/3783)		
	16	Overhead guard height	Std/opt/opt flat plate		in (mm) 94/91/87.1 (2388/2311/2212)		
	17	Sip to bottom std OHG	Susp at mid-point	Std/susp/swivel	in (mm) 37.3/36.3/36.2 (949/924/922)		
	18	Tow pin height	Vertical center of pin		in (mm) 12.7 (324)		
	19	Overall width	Standard tread/wide tread		in (mm) 47.2/50 (1200/1270)		
	20	Forks	Thickness x width x length		in (mm) 2 x 4.9 x 42 (50 x 125 x 1067)		
	21	Standard carriage width	Class III		in (mm) 42 (1067)		
	22	Floor to top of battery rollers			in (mm) 20 (509)		
	23	Ground clearance	Lowest point	NL/RL	in (mm) 3.8/3.5 (96/90)		
	24	Ground clearance	Center of truck	NL/RL	in (mm) 5.3/5.1 (134/130)		
	25	Load distance	Center of wheel to face of forks		in (mm) 17.6 (447)		
	26	Battery compartment	Height	Without/with battery rollers	in (mm) 24.5/24 (622/609)		
			Width		in (mm) 45.4 (1152)		
				Nominal	SIZE 39		
			Length	Actual	in (mm) 39.2 (996)		
	27	Length to face of forks	Chassis length		in (mm) 96.5 (2451)		
	28	Wheelbase			in (mm) 62 (1574)		
	29	Right angle stack			in (mm) 150.8 (3831)		
30	Equal aisle	90° intersecting aisle		in (mm) 79.4 (2017)			
31	Outside turning radius			in (mm) 85.2 (2165)			
WEIGHT	32	Truck weight	Without battery	NL	lb (kg) 11070 (5021)		
	33	Axle loading - drive	Static with max. wt. battery	NL/RL	lb (kg) 6728/20098 (3052/9116)		
	34	Axle loading - steer	Static with max. wt. battery	NL/RL	lb (kg) 9141/3771 (4146/1710)		
PERFORMANCE					STANDARD PERFORMANCE		
					VOLTS 36 48 80		
	36	Travel speed	Extended shift off	NL/RL	mph (km/h) 11.2/9.9 (18/15.9)	11.7/11.4 (18.8/18.3)	11.7/11.2 (18.8/18)
			Extended shift on	NL/RL	mph (km/h) 9/8.1 (14.5/13)	10.9/10.4 (17.5/16.7)	10.9/10.8 (17.5/17.4)
	37	Lift speed	Std 2-stg FFL mast	NL/RL	ft/min (m/sec) 94/58 (0.48/0.296)	118/73 (0.6/0.37)	118/73 (0.6/0.37)
			Opt 2-stg FFL mast	NL/RL	ft/min (m/sec) 85/53 (0.4336/0.267)	107/66 (0.542/0.334)	107/66 (0.542/0.334)
			Opt 3-stg FFL mast	NL/RL	ft/min (m/sec) 88/54 (0.448/0.276)	110/68 (0.56/0.345)	110/68 (0.56/0.345)
	38	Lower speed	Std 2-stg FFL mast	NL/RL	ft/min (m/sec) 94/104 (0.48/0.53)		
			Opt 2-stg FFL mast	NL/RL	ft/min (m/sec) 75/91 (0.38/0.46)		
			Opt 3-stg FFL mast	NL/RL	ft/min (m/sec) 77/98 (0.39/0.5)		
	39	Gradeability	5 minute rating	NL/RL	% 23/14.1	29.3/17.8	30.1/18.3
			60 minute rating	NL/RL	% 8.4/5.4	10.6/6.8	10.9/7
	40	Drawbar pull	5 minute rating	NL/RL	LBF 3327/3193	4023/3864	4104/3941
			60 minute rating	NL/RL	LBF 1246/1232	1511/1497	1541/1526
	41	Brake	Method of control	Service/parking	Hydraulic/spring applied		
		Method of operation	Service/parking	Foot/automatic			
42	Battery			Type Lead acid Thin Plate Pure Lead* Lithium-ion*			
				STANDARD PERFORMANCE			
				VOLTS 36 48 80			
43	Traction motor		60 minute rating	hp (kW) 28.8 (21.5)	28.8 (21.5)	28.2 (21)	
44	Pump motor		15% rating	hp (kW) 35.5 (26.5)	48.3 (36)	48.3 (36)	
45	Traction motor		Type/control method	AC/transistor			
46	Pump motor		Type/control method	AC/transistor			
47	Number of speeds			Traction/pump Infinitely variable/infinitely variable			
48	Step height			in (mm) 21.1 (536)			
49	Floor height		Lowest point	in (mm) 33.7 (855)			
50	Attachment relief pressure			psi (bar) 2250 (155)			
51	Auxiliary oil flow	3rd and 4th function		gal/min (l/min) 16 (60)			
52	Sound Level			Measured per ANSI B56.11.5 dB (A) 69/66			

* Optional with Hyster Power Collect™

Above specifications, unless otherwise listed, are for a standard truck without optional equipment. Right angle stack and equal intersecting aisle dimensions provided with a 48" long and 40" wide pallet load, allowing zero clearance.

CERTIFICATION: Hyster® lift trucks meet the design and construction requirements of B56.1-1969, per OSHA Section 1910.178(a)(2), and also comply with the B56.1 revision in effect at time of manufacture. Certification of compliance with the applicable ANSI standards appears on the lift truck. Performance specifications are for a truck equipped as described under standard equipment on this technical guide. Performance specifications are affected by the condition of the vehicle and how it is equipped, as well as by the nature, condition of the operating area, proper service and maintenance of the vehicle. If these specifications are critical, the proposed application should be discussed with your dealer.

E100XNS DIMENSIONS

GENERAL	1	Manufacturer			Hyster			
	2	Model designation			E100XNS			
	3	Power			Electric			
	4	Operation			Sit			
	5	Rated capacity		lb (kg)	10000 (4536)			
	6	Load center		in (mm)	24 (610)			
TIRES / WHEELS	7	Tire type - cushion, solid, pneumatic, etc.		Drive/steer	Cushion/cushion			
	8	Tire size		Drive/steer	in 22 x 12 x 16 / 18 x 7 x 12.1			
	9	Wheels - number	X=driven	Drive/steer	2x/2			
DIMENSIONS	10	Tread	Center of tires	Nar dr/wide dr/steer	in (mm)	40/43.9/38.3 (1015/1115/972)		
	11	Mast tilt		Std opt	degrees	5F/5B 8F/5B		
	12	Mast - lowered height		Std mast	in (mm)	85 (2138)		
	13	Free lift - top of fork	Std 2-stg limited free lift mast		in (mm)	5 (150)		
			Opt 2-stg full free lift mast with/without LBR		in (mm)	35/48 (897/1222)		
	14	Lift height - top of fork	Std 2-stg limited free lift mast		in (mm)	109 (2790)		
	15	Mast - extended height		Std mast with/without LBR	in (mm)	159/144 (4031/3657)		
	16	Overhead guard height	Std/opt/opt flat plate		in (mm)	94/91/87.1 (2388/2311/2212)		
	17	Sip to bottom std OHG	Susp at mid-point	Std/susp/swivel	in (mm)	37.3/36.3/36.2 (949/924/922)		
	18	Tow pin height	Vertical center of pin		in (mm)	12.7 (324)		
	19	Overall width	Standard tread/wide tread		in (mm)	52/55.9 (1320/1420)		
	20	Forks	Thickness x width x length		in (mm)	2 x 5.9 x 42 (50 x 150 x 1067)		
	21	Standard carriage width	Class III		in (mm)	42 (1067)		
	22	Floor to top of battery rollers			in (mm)	20 (509)		
	23	Ground clearance	Lowest point	NL/RL	in (mm)	3.6/3.4 (92/87)		
	24	Ground clearance	Center of truck	NL/RL	in (mm)	5.3/5.1 (134/130)		
	25	Load distance	Center of wheel to face of forks		in (mm)	17.8 (452)		
	26	Battery compartment	Height	Without/with battery rollers	in (mm)	24.5/24 (622/609)		
			Width		in (mm)	45.4 (1152)		
				Nominal	SIZE	39"		
			Length	Actual	in (mm)	39.2 (996)		
	27	Length to face of forks	Chassis length		in (mm)	100.3 (2548)		
	28	Wheelbase			in (mm)	62 (1574)		
	29	Right angle stack			in (mm)	154 (3911)		
30	Equal aisle	90° intersecting aisle		in (mm)	83 (2107)			
31	Outside turning radius			in (mm)	88.2 (2240)			
WEIGHT	32	Truck weight	Without battery	NL	lb (kg)	13070 (5928)		
	33	Axle loading - drive	Static with max. wt. battery	NL/RL	lb (kg)	6798/23542 (3084/10678)		
	34	Axle loading - steer	Static with max. wt. battery	NL/RL	lb (kg)	11069/4325 (5021/1962)		
PERFORMANCE					STANDARD PERFORMANCE			
					VOLTS	36	48	80
	36	Travel speed	Extended shift off	NL/RL	mph (km/h)	10.3/8.8 (16.6/14.2)	11.4/11 (18.3/17.7)	11.4/11 (18.3/17.7)
			Extended shift on	NL/RL	mph (km/h)	8.8/7.6 (14.2/12.3)	10.9/9.9 (17.5/15.9)	10.9/9.9 (17.5/15.9)
	37	Lift speed	Std 2-stg LFL mast	NL/RL	ft/min (m/sec)	71/46 (0.36/0.232)	89/57 (0.45/0.29)	89/57 (0.45/0.29)
			Opt 2-stg FFL mast	NL/RL	ft/min (m/sec)	67/43 (0.34/0.219)	84/54 (0.425/0.274)	84/54 (0.425/0.274)
			Opt 3-stg FFL mast	NL/RL	ft/min (m/sec)	68/44 (0.346/0.223)	85/55 (0.433/0.275)	85/55 (0.433/0.279)
	38	Lower speed	Std 2-stg LFL mast	NL/RL	ft/min (m/sec)		73/89 (0.37/0.45)	
			Opt 2-stg FFL mast	NL/RL	ft/min (m/sec)		57/81 (0.29/0.41)	
			Opt 3-stg FFL mast	NL/RL	ft/min (m/sec)		63/87 (0.32/0.44)	
	39	Gradeability	5 minute rating	NL/RL	%	19.4/11.8	24.6/14.7	25.2/15.1
			60 minute rating	NL/RL	%	7.1/4.5	9.1/5.6	9.2/5.8
40	Drawbar pull	5 minute rating	NL/RL	LBF	3323/3185	3994/3832	4074/3909	
		60 minute rating	NL/RL	LBF	1242/1224	1497/1479	1527/1509	
41	Brake	Method of control	Service/parking	Hydraulic/spring applied				
		Method of operation	Service/parking	Foot/automatic				
42	Battery		Type	Lead acid Thin Plate Pure Lead* Lithium-ion*				
				STANDARD PERFORMANCE				
				VOLTS	36	48	80	
ELECTRIC	43	Traction motor		60 minute rating	hp (kW)	28.8 (21.5)	28.8 (21.5)	28.2 (21)
	44	Pump motor		15 % rating	hp (kW)	35.5 (26.5)	48.3 (36)	48.3 (36)
	45	Traction motor		Type/control method	AC/transistor			
	46	Pump motor		Type/control method	AC/transistor			
	47	Number of speeds		Traction/pump	Infinitely variable/infinitely variable			
OTHER	48	Step height			in (mm)	21.1 (536)		
	49	Floor height		Lowest point	in (mm)	33.7 (855)		
	50	Attachment relief pressure			psi (bar)	2250 (155)		
	51	Auxiliary oil flow	3rd and 4th function		gal/min (l/min)	16 (60)		
	52	Sound level		Measured per ANSI B56.11.5		dB (A) 69/66		

* Optional with Hyster Power Collect™

Above specifications, unless otherwise listed, are for a standard truck without optional equipment. Right angle stack and equal intersecting aisle dimensions provided with a 48" long and 40" wide pallet load, allowing zero clearance.

CERTIFICATION: Hyster® lift trucks meet the design and construction requirements of B56.1-1969, per OSHA Section 1910.178(a)(2), and also comply with the B56.1 revision in effect at time of manufacture. Certification of compliance with the applicable ANSI standards appears on the lift truck. Performance specifications are for a truck equipped as described under standard equipment on this technical guide. Performance specifications are affected by the condition of the vehicle and how it is equipped, as well as by the nature, condition of the operating area, proper service and maintenance of the vehicle. If these specifications are critical, the proposed application should be discussed with your dealer.

E100XN SPECIFICATIONS

GENERAL	1	Manufacturer			Hyster			
	2	Model designation			E100XN			
	3	Power			Electric			
	4	Operation			Sit			
	5	Rated capacity		lb (kg)	10000 (4536)			
	6	Load center		in (mm)	24 (610)			
TIRES/ WHEELS	7	Tire type - cushion, solid, pneumatic, etc.		Drive/steer	Cushion/cushion			
	8	Tire size		Drive/steer	22 x 12 x 16 / 18 x 7 x 12.1			
	9	Wheels - number	X=driven	Drive/steer	2x2			
DIMENSIONS	10	Tread	Center of tires	Nar dr/wide dr/steer	in (mm)	40/43.9/38.3 (1015/1115/972)		
	11	Mast tilt		Std opt	degrees	5F/5B 8F/5B		
	12	Mast - lowered height		Std mast	in (mm)	85 (2138)		
	13	Free lift - top of fork		Std 2-stg limited free lift mast	in (mm)	5 (150)		
				Opt 2-stg full free lift mast with/without LBR	in (mm)	35/48 (897/1222)		
	14	Lift height - top of fork		Std 2-stg limited free lift mast	in (mm)	109 (2790)		
	15	Mast - extended height		Std mast with/without LBR	in (mm)	159/144 (4031/3657)		
	16	Overhead guard height		Std/opt/opt flat plate	in (mm)	94/91/87.1 (2388/2311/2212)		
	17	Sip to bottom std OHG	Susp at mid-point	Std/susp/swivel	in (mm)	37.3/36.3/36.2 (949/924/922)		
	18	Tow pin height		Vertical center of pin	in (mm)	12.7 (324)		
	19	Overall width		Standard tread/wide tread	in (mm)	52/55.9 (1320/1420)		
	20	Forks		Thickness x width x length	in (mm)	2 x 5.9 x 42 (50 x 150 x 1067)		
	21	Standard carriage width		Class III	in (mm)	42 (1067)		
	22	Floor to top of battery rollers			in (mm)	20 (509)		
	23	Ground clearance	Lowest point	NL/RL	in (mm)	3.6/3.4 (92/87)		
	24	Ground clearance	Center of truck	NL/RL	in (mm)	5.3/5.1 (134/130)		
	25	Load distance		Center of wheel to face of forks	in (mm)	17.8 (452)		
	26	Battery compartment		Height	Without/with battery rollers	in (mm)	24.5/24 (622/609)	
				Width		in (mm)	45.4 (1152)	
				Nominal	SIZE	45"		
		Length	Actual	in (mm)	45.7 (1161)			
27	Length to face of forks		Chassis length	in (mm)	103.1 (2621)			
28	Wheelbase			in (mm)	68.5 (1739)			
29	Right angle stack			in (mm)	158 (4012)			
30	Equal aisle	90° intersecting aisle		in (mm)	84.3 (2141)			
31	Outside turning radius			in (mm)	92.2 (2341)			
WEIGHT	32	Truck weight	Without battery	NL	lb (kg)	12300 (5579)		
	33	Axle loading - drive	Static with max. wt. battery	NL/RL	lb (kg)	7708/23813 (3496/10801)		
	34	Axle loading - steer	Static with max. wt. battery	NL/RL	lb (kg)	10139/4035 (4599/1830)		
PERFORMANCE					STANDARD PERFORMANCE			
					VOLTS	36	48	80
	36	Travel speed		Extended shift off	NL/RL	mph (km/h)	10.3/8.8 (16.6/14.2)	11.4/11 (18.3/17.7)
				Extended shift on	NL/RL	mph (km/h)	8.8/7.6 (14.2/12.3)	10.9/9.9 (17.5/15.9)
	37	Lift speed		Std 2-stg LFL mast	NL/RL	ft/min (m/sec)	71/46 (0.36/0.232)	89/57 (0.45/0.29)
				Opt 2-stg FFL mast	NL/RL	ft/min (m/sec)	67/43 (0.34/0.219)	84/54 (0.425/0.274)
				Opt 3-stg FFL mast	NL/RL	ft/min (m/sec)	68/44 (0.346/0.223)	85/55 (0.433/0.279)
	38	Lower speed		Std 2-stg LFL mast	NL/RL	ft/min (m/sec)	73/89 (0.37/0.45)	
				Opt 2-stg FFL mast	NL/RL	ft/min (m/sec)	57/81 (0.29/0.41)	
				Opt 3-stg FFL mast	NL/RL	ft/min (m/sec)	63/87 (0.32/0.44)	
	39	Gradeability		5 minute rating	NL/RL	%	19.9/11.9	25.2/15
				60 minute rating	NL/RL	%	7.3/4.5	9.4/5.9
40	Drawbar pull		5 minute rating	NL/RL	LBF	3322/3185	3970/3809	
			60 minute rating	NL/RL	LBF	1241/1224	1488/1470	
41	Brake		Method of control	Service/parking	Hydraulic/spring applied			
			Method of operation	Service/parking	Foot/automatic			
42	Battery		Type	Lead acid Thin Plate Pure Lead* Lithium-ion*				
ELECTRIC					STANDARD PERFORMANCE			
					VOLTS	36	48	80
	43	Traction motor		60 minute rating	hp (kW)	28.8 (21.5)	28.8 (21.5)	28.2 (21)
	44	Pump motor		15% rating	hp (kW)	35.5 (26.5)	48.3 (36)	48.3 (36)
	45	Traction motor		Type/control method	AC/transistor			
	46	Pump motor		Type/control method	AC/transistor			
	47	Number of speeds		Traction/pump	Infinitely variable/infinitely variable			
OTHER	48	Step height		in (mm)	21.1 (536)			
	49	Floor height		Lowest point	in (mm)	33.7 (855)		
	50	Attachment relief pressure			psi (bar)	2250 (155)		
	51	Auxiliary oil flow	3rd and 4th function		gal/min (l/min)	16 (60)		
	52	Sound level		Measured per ANSI B56.11.5	dB (A)	69/66		

* Optional with Hyster Power Collect™

Above specifications, unless otherwise listed, are for a standard truck without optional equipment.

Right angle stack and equal intersecting aisle dimensions provided with a 48" long and 40" wide pallet load, allowing zero clearance.

CERTIFICATION: Hyster® lift trucks meet the design and construction requirements of B56.1-1969, per OSHA Section 1910.178(a)(2), and also comply with the B56.1 revision in effect at time of manufacture. Certification of compliance with the applicable ANSI standards appears on the lift truck. Performance specifications are for a truck equipped as described under standard equipment on this technical guide. Performance specifications are affected by the condition of the vehicle and how it is equipped, as well as by the nature, condition of the operating area, proper service and maintenance of the vehicle. If these specifications are critical, the proposed application should be discussed with your dealer.

E120XN DIMENSIONS

GENERAL	1	Manufacturer		Hyster			
	2	Model designation		E120XN			
	3	Power		Electric			
	4	Operation		Sit			
	5	Rated capacity		12000 (5443)			
	6	Load center		24 (610)			
TIRES/ WHEELS	7	Tire type - cushion, solid, pneumatic, etc.		Cushion/cushion			
	8	Tire size		22 x 12 x 16 / 18 x 7 x 12.1			
	9	Wheels - number		2x/2			
DIMENSIONS	10	Tread		40/43.9/38.3 (1015/1115/972)			
	11	Mast tilt		5F/5B 8F/5B			
	12	Mast - lowered height		85 (2138)			
	13	Free lift - top of fork		5 (150)			
		Std 2-stg limited free lift mast					
		Opt 2-stg full free lift mast with/without LBR		35/48 (897/1222)			
	14	Lift height - top of fork		109 (2790)			
	15	Mast - extended height		159/144 (4031/3657)			
	16	Overhead guard height		94/91/87.1 (2388/2311/2212)			
	17	Sip to bottom std OHG		37.3/36.3/36.2 (949/924/922)			
	18	Tow pin height		12.7 (324)			
	19	Overall width		52/55.9 (1320/1420)			
	20	Forks		2.4 x 5.9 x 42 (60 x 150 x 1067)			
	21	Standard carriage width		42 (1067)			
	22	Floor to top of battery rollers		20 (509)			
	23	Ground clearance		3.6/3.4 (92/87)			
	24	Ground clearance		5.3/5.1 (134/130)			
	25	Load distance		18.2 (462)			
	26	Battery compartment		24.5/24 (622/609)			
		Height					
		Width		45.4 (1152)			
		Nominal SIZE		45"			
		Length		45.7 (1161)			
	27	Length to face of forks		107.2 (2724)			
	28	Wheelbase		68.5 (1739)			
	29	Right angle stack		161.5 (4101)			
30	Equal aisle		85.7 (2178)				
31	Outside turning radius		95.3 (2420)				
WEIGHT	32	Truck weight		13810 (6264)			
		Without battery		NL			
	33	Axle loading - drive		7466/26860 (3387/12183)			
	34	Axle loading - steer		11886/4491 (5391/2037)			
	Static with max. wt. battery		NL/RL				
	Static with max. wt. battery		NL/RL				
PERFORMANCE	STANDARD PERFORMANCE						
				VOLTS	36	48	80
	36	Travel speed		mph (km/h)			
		Extended shift off		9.4/8 (15.1/12.9)			
		Extended shift on		8.2/7 (13.2/11.3)			
	37	Lift speed		ft/min (m/sec)			
		Std 2-stg LFL mast		71/43 (0.36/0.216)			
		Opt 2-stg FFL mast		67/40 (0.34/0.204)			
		Opt 3-stg FFL mast		68/41 (0.346/0.208)			
	38	Lower speed		ft/min (m/sec)			
		Std 2-stg LFL mast		73/89 (0.37/0.45)			
		Opt 2-stg FFL mast		57/81 (0.29/0.41)			
		Opt 3-stg FFL mast		63/87 (0.32/0.44)			
39	Gradeability		%				
	5 minute rating		18.5/10.4				
	60 minute rating		6.6/4				
40	Drawbar pull		LBF				
	5 minute rating		3320/3179				
	60 minute rating		1239/1218				
41	Brake		Hydraulic/spring applied				
	Method of control		Service/parking				
	Method of operation		Foot/automatic				
42	Battery		Type				
			Lead acid Thin Plate Pure Lead* Lithium-ion*				
ELECTRIC	STANDARD PERFORMANCE						
				VOLTS	36	48	80
	43	Traction motor		hp (kW)			
		60 minute rating		28.8 (21.5)			
	44	Pump motor		hp (kW)			
		15% rating		35.5 (26.5)			
	45	Traction motor		AC/transistor			
46	Pump motor		AC/transistor				
47	Number of speeds		Traction/pump				
			Infinitely variable/infinitely variable				
OTHER	48	Step height		in (mm)			
				21.1 (536)			
	49	Floor height		in (mm)			
		Lowest point		33.7 (855)			
	50	Attachment relief pressure		psi (bar)			
			2250 (155)				
51	Auxiliary oil flow		gal/min (l/min)				
	3rd and 4th function		16 (60)				
52	Sound level		Measured per ANSI B56.11.5				
			dB (A)				
			69/66				

* Optional with Hyster Power Collect™

Above specifications, unless otherwise listed, are for a standard truck without optional equipment. Right angle stack and equal intersecting aisle dimensions provided with a 48" long and 40" wide pallet load, allowing zero clearance.

CERTIFICATION: Hyster® lift trucks meet the design and construction requirements of B56.1-1969, per OSHA Section 1910.178(a)(2), and also comply with the B56.1 revision in effect at time of manufacture. Certification of compliance with the applicable ANSI standards appears on the lift truck. Performance specifications are for a truck equipped as described under standard equipment on this technical guide. Performance specifications are affected by the condition of the vehicle and how it is equipped, as well as by the nature, condition of the operating area, proper service and maintenance of the vehicle. If these specifications are critical, the proposed application should be discussed with your dealer.

MAST DIMENSIONS AND BATTERY SPECIFICATIONS

E80XN MAST DIMENSIONS

Maximum fork height (TOF) +	Overall lowered height	Overall extended height w/load backrest	Overall extended height w/o load backrest	Free-lift (TOF) w/ load backrest	Free-lift (TOF) w/o load backrest
in (mm)	in (mm)	in (mm)	in (mm)	in (mm)	in (mm)
2-STAGE LIMITED FREE-LIFT (LFL) MAST					
120 (3050)	84 (2134)	176 (4455)	149 (3783)	5 (150)	5 (150)
143 (3650)	96 (2434)	193 (4884)	173 (4383)	5 (150)	5 (150)
2-STAGE FULL FREE-LIFT (FFL) MAST					
121 (3075)	84 (2134)	170 (4309)	152 (3857)	35 (900)	53 (1352)
144 (3675)	96 (2434)	194 (4909)	176 (4457)	47 (1200)	65 (1652)
3-STAGE FULL FREE-LIFT (FFL) MAST					
173 (4415)	84 (2134)	223 (5649)	205 (5197)	35 (900)	53 (1352)
185 (4715)	88 (2234)	235 (5949)	217 (5497)	39 (1000)	57 (1452)
194 (4950)	92 (2334)	244 (6184)	226 (5732)	43 (1100)	61 (1552)
218 (5550)	100 (2534)	268 (6784)	250 (6332)	51 (1300)	69 (1752)

E100XNS, E100XN, E120XN MAST DIMENSIONS

Maximum fork height (TOF) +	Overall lowered height	Overall extended height w/load backrest	Overall extended height w/o load backrest	Free-lift (TOF) w/ load backrest	Free-lift (TOF) w/o load backrest
in (mm)	in (mm)	in (mm)	in (mm)	in (mm)	in (mm)
2-STAGE LIMITED FREE-LIFT (LFL) MAST					
109 (2790)	85 (2138)	159 (4031)	144 (3657)	5 (150)	5 (150)
133 (3390)	96 (2438)	183 (4631)	168 (4257)	5 (150)	5 (150)
157 (3990)	108 (2738)	206 (5231)	192 (4857)	5 (150)	5 (150)
2-STAGE FULL FREE-LIFT (FFL) MAST					
110 (2815)	85 (2138)	160 (4056)	147 (3731)	35 (897)	48 (1222)
134 (3415)	96 (2438)	184 (4656)	171 (4331)	47 (1197)	59 (1522)
3-STAGE FULL FREE-LIFT (FFL) MAST					
162 (4137)	85 (2138)	212 (5378)	200 (5058)	35 (897)	47 (1217)
184 (4690)	92 (2338)	234 (5931)	221 (5611)	43 (1097)	55 (1417)
208 (5290)	100 (2538)	258 (6531)	245 (6211)	51 (1297)	63 (1617)

BATTERY AND COMPARTMENT SPECIFICATIONS

Truck model	Battery compartment dimensions			Battery dimensions and specifications			Volts	No. of cells	Plates per cell	Max capacity 6 hour rate amp hr (kwh)	Weight	
	Width	Length	Height	"X"	"Y"	"Z"					Min	Max
	in (mm)			in (mm)							lb (kg)	
E80XN E100XNS 39" Compartment	45.4 (1152)	39.2 (996)	24.5 (622)	45 (1143)	39 (990)	23.9 (608)	36	18	33	2300 (80.3)	3400 (1542)	4800 (2177)
							48	24	29	1800 (83.8)		
							80	40	15	1000 (77.6)		
E100XN E120XN 45" Compartment	45.4 (1152)	45.7 (1161)	24.5 (622)	45 (1143)	45.3 (1150)	23.9 (608)	36	36	19	2300 (160.6)	4000 (1814)	5500 (2517)
							48	24	33	1800 (83.8)		
							80	40	17	1000 (77.6)		

Battery type: "EO" (without cover)
 Battery amp hr (kwh) capacity is max allowable per UL
 Commercially available lead acid batteries may not necessarily reach these max limits
 Battery roller option reduces battery compartment height to 24.0" (609mm) & max battery height to 23.4" (595mm)
 Battery compartment length is measured front to rear. Battery compartment width is measured across the truck

Battery notes – Conventional charging (BCSSBC)
 Battery connector: 36-volt - Gray SB®350 (Anderson Power Products® P/N 6320G2 or equivalent)
 48-volt - Blue SB®350 (Anderson Power Products® P/N 6321G2 or equivalent)
 80-volt - Black SBE®320 (Anderson Power Products® P/N E6359G3 or equivalent)
 Handle (not required): SB®350 and SBE®320 (Anderson Power Products®: "A" TYPE (gray) P/N 995G2 or equivalent)
 Battery lead: length 20" (508 mm), position "B", 4/0 AWG

Battery notes – Rapid/fast charging (BARFBC)
 Battery connector: Requires dual positive/negative cabling terminating in (2) Female EBC-320 DIN connectors (Anderson Power Products® P/N E32504-00X9 or equivalent)
 Each individual DIN connector to include 1 red conductor to (+) and 1 black conductor to (-)
 Battery lead: Length 25" (635 mm), position "B", minimum cable size 4/0 AWG

E80-120XN FEATURES AND OPTIONS

PERFORMANCE	STD	OPT
36-volt electrical system	x	
AC traction and pump motors (completely brushless)	x	
Transistor drive and pump control	x	
Advanced VSM (Vehicle System Manager)	x	
Regenerative braking	x	
48-volt electrical system		x
80-volt electrical system		x
DRIVE	STD	OPT
Smooth tread rubber drive tire and steer tire	x	
Non-marking, rubber, or lug tread tires		x
Wide tread tires		x
LIFT	STD	OPT
2-stage limited free lift (LFL) mast with maximum fork height of 120" (3050mm) (E80XN)	x	
2-stage limited free lift (LFL) mast with maximum fork height of 109" (2790mm) (E100-120XN)	x	
5° forward and 5° back mast tilt	x	
2-stage full free lift mast		x
3-stage full free lift mast		x
8° forward/5° back tilt		x
HANDLING	STD	OPT
42" (1067mm) wide hook-type carriage with 48" (1219mm) high load backrest extension	x	
42" (1067mm) long forks	x	
48" (1220mm) wide hook type carriage w/ 48" high load backrest extension		x
42" (1067mm) wide attachment carriage (E100XN/XNS)		x
42" (1067mm) wide integral side shift (E80XN)		x
48" (1220mm) integral sideshift carriage		x
Multiple fork lengths		x
Return to set tilt		x
Hydraulic attachment extension tubes with or without quick disconnect fittings		x
Load weight indicator		x
Accumulator		x
ERGONOMICS	STD	OPT
Foot directional control pedal	x	
Mechanical hydraulic levers	x	
Steering wheel w/integral spinner knob	x	
Non-suspension vinyl seat	x	
Black, non-cinch seat belt with Emergency Locking Retractor (ELR)	x	
Automatic park brake	x	
Power assist braking	x	
On-demand hydrostatic power-assist steering	x	
Auto Deceleration System (ADS)	x	
Multifunction display (high mount)	x	
Easy ingress/egress with low step height and contoured handhold	x	
Operator convenience station	x	
Adjustable tilt steering column	x	
Operator Presence System (OPS)	x	
Cushioned floormat	x	
Seatside power disconnect button	x	
Non-suspension cloth seat		x
Full-suspension seat (vinyl or cloth)		x

ERGONOMICS (continued)	STD	OPT
Full-suspension swivel seat (vinyl or cloth)		x
Seatside directional control		x
Telescoping steering column with tilt memory		x
LED dome/reading light		x
Rear drive handle with horn button		x
Dual rear view mirrors		x
Panoramic rear view mirror		x
Red, high-visibility, non-cinch seat belt with or without interlock		x
Low mount display		x
TouchPoint mini-levers		x
OPERATION	STD	OPT
Standard environmental construction	x	
Key switch start	x	
94" grid style overhead guard	x	
3-function hydraulic control valve	x	
Fully integrated CANbus communication	x	
Battery removal without rollers - lift out	x	
Static strap	x	
Tow pin	x	
Type "E" UL construction	x	
Hyster Stability System (HSS®)	x	
Cooler/freezer package – operating temperatures: -20°F to +120° F		x
4-function hydraulic control valve		x
Horizontal Battery Extraction (rollers)		x
Keyless start (with auxiliary key switch)		x
LED brake/tail/back-up light packages		x
LED and halogen work light packages		x
Key switch controlled lights		x
Audible alarm - reverse operation (manually adjustable to 87, 97 or 102 dB)		x
Visible amber strobe light - continuous activated, overhead guard mounted		x
Fire extinguisher - 2.5lb dry chemical		x
Impact monitor with programmable shutdown		x
Operator password start interlock		x
Operator daily checklist		x
System monitor - hydraulic low fluid level indicator and hydraulic filter service indicator		x
Programmable maintenance reminder		x
Rapid/fast charge		x
Type "EE" UL construction		x
12-volt auxiliary power supply		x
Auxiliary DC-DC converter		x
91" grid style overhead guard		x
87" flat plate overhead guard		x
Hyster Reaction™		x
SUPPLEMENTAL	STD	OPT
Operating manual	x	
12 month/2,000 hour full truck warranty	x	
36 month/6,000 hour powertrain warranty	x	
ENERGY SYSTEM	STD	OPT
Lead acid	x	
Hyster Power Collect™		x



Hyster Company
P.O. Box 7006
Greenville, North Carolina
27835-7006

© 2023 Hyster Company. All rights reserved. Hyster and  are trademarks of Hyster-Yale Group, Inc.

Hyster products are subject to change without notice. Trucks may be shown with optional equipment.