



R30XMF3 SERIES

NARROW AISLE ORDER PICKER
PRODUCT TECHNICAL GUIDE



R30XMF3 DIMENSIONS

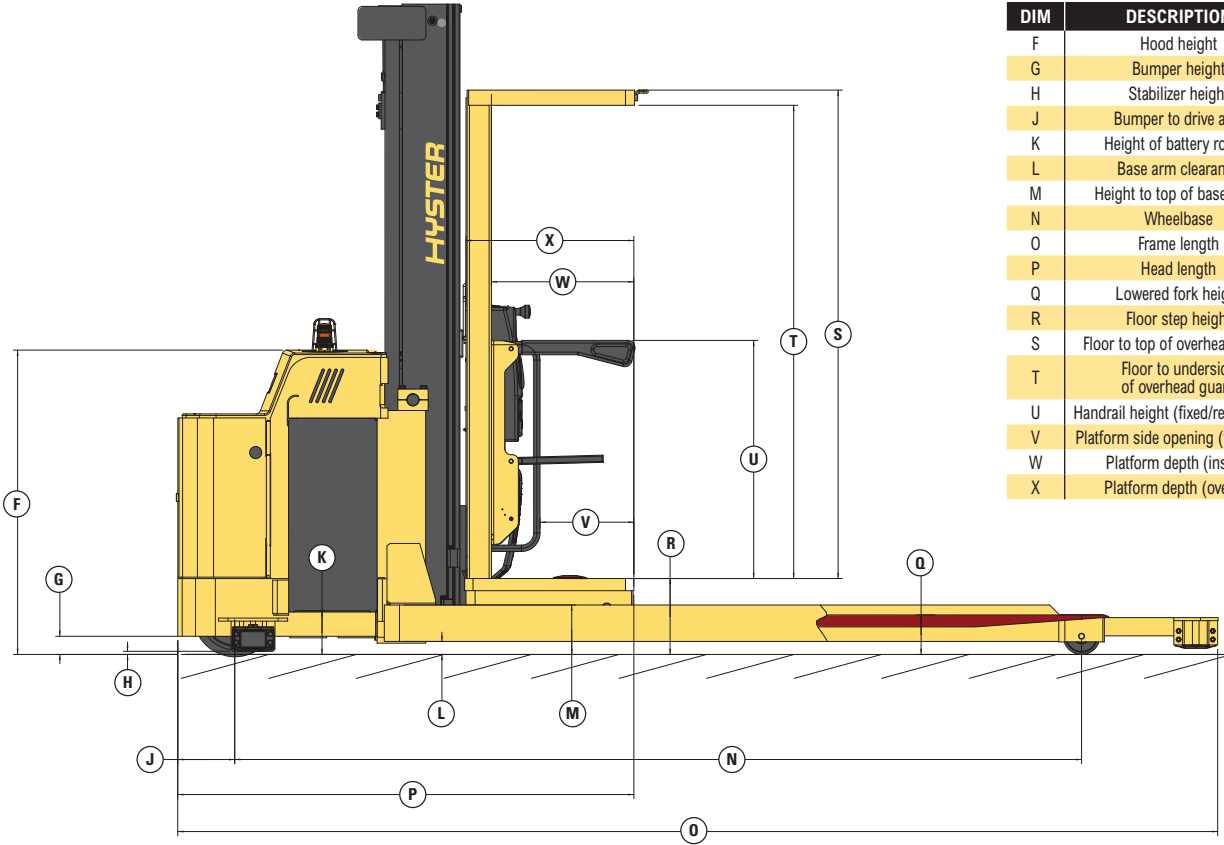

DIM	DESCRIPTION	VALUE in (mm)
F	Hood height	50.0 (1272)
G	Bumper height	3.0 (76)
H	Stabilizer height	0.5 (13.1)
J	Bumper to drive axle	9.4 (238)
K	Height of battery rollers	7.2 (182)
L	Base arm clearance	2.1 (54)
M	Height to top of base arms	8.1 (207)
N	Wheelbase	139.4 (3540)
O	Frame length	171.2 (4349)
P	Head length	75.1 (1907)
Q	Lowered fork height	6.5 (165)
R	Floor step height	12.5 (317)
S	Floor to top of overhead guard	80.4 (2042)
T	Floor to underside of overhead guard	77.9 (1978)
U	Handrail height (fixed/retractable)	39.0/39.2 (990/995)
V	Platform side opening (fixed rail)	15.4 (392)
W	Platform depth (inside)	23.4 (595)
X	Platform depth (overall)	27.6 (702)

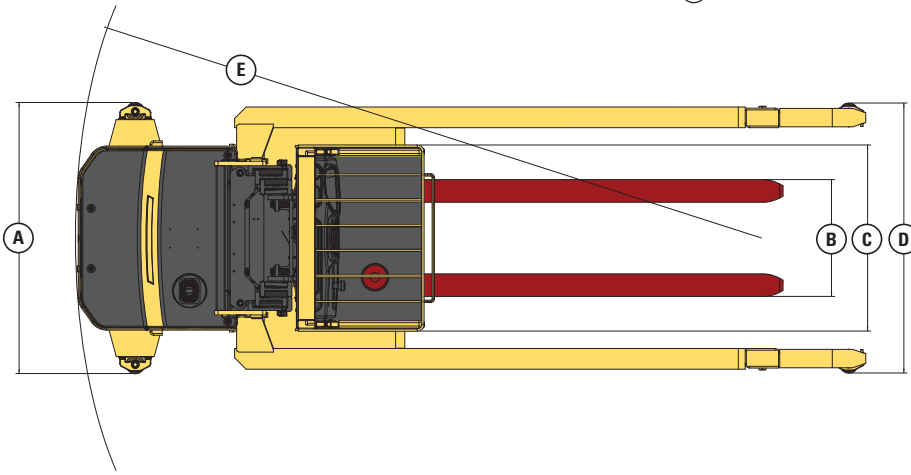

DIM	DESCRIPTION	VALUE in (mm)
A	Frame width	52.5 (1334)
		54.5 (1384)
		56.8 (1443)
		58.5 (1486)
B	Fork width	22.8 to 28.0 (580 to 711)
C	Platform width	40.2 (1022)
D	Overall width	52.5 (1334)
		54.5 (1384)
		56.8 (1443)
		58.5 (1486)
E	Turning radius	149 (3793)

MAST PERFORMANCE

		Lifting speed		Lowering speed	
		Empty	Rated load †	Empty	Rated load †
24V DC	67 ft/min (0.340 m/s)	45 ft/min (0.229 m/s)	80 ft/min (0.406 m/s)	80 ft/min (0.406 m/s)	
36V DC	78 ft/min (0.396 m/s)	63 ft/min (0.320 m/s)	80 ft/min (0.406 m/s)	80 ft/min (0.406 m/s)	

† Rated load figures are based on 1500 lb load (680 kg) and a 48" load center.
NOTE: Performance specifications are for truck with standard equipment. Performance specifications are affected by the condition of the vehicle and how it is equipped as well as the nature and condition of the operating area. If these specifications are critical, the proposed application should be discussed with your dealer.

MAST DIMENSIONS

	Maximum fork height (TOF)	Overall lowered height	Overall extended height
	in (mm)	in (mm)	in (mm)
3-stage (6.9)	240 (6096)	107 (2718)	327 (8306)
	270 (6858)	119 (3023)	357 (9068)
	300 (7620)	131 (3325)	387 (9830)
	330 (8382)	143 (3632)	417 (10592)
	360 (9144)	155 (3937)	447 (11354)

Lift heights over 360" (9144 mm) maximum fork height may require reduced capacity depending upon OEC dimensions.

R30XMF3 SPECIFICATIONS

		Hyster	
GENERAL	1	Manufacturer	R30XMF3
	2	Model designation	R30XMF3
	3	Power/voltage	Electric/24-volts Electric/36-volts
	4	Operation type	Stand-up
	5	Rated capacity	1500 (680)
DIMENSIONS	6	Load center	48 (1219)
	7	Tire type, front/rear	load/drive
	8	Wheels (X=driven)	front/rear
	9	Mast – 3-stage (TOF)	
	10	Operator clearance height	See mast chart
	11	Forks, width/thickness	77.9 (1978)
	12	Fork spread, inside to inside	5/2 (130/50)
	13	Fork spread, outside to outside	13/18 (330/457)
	14	Top of fork, mast lowered	23/28 (584/710)
	15	Head length, length to face of operator deck	6.5 (165)
	16	Base width	75.1 (1907)
PERFORM.	17	Height, standard 3-stage mast lowered	See chart
	18	Operator platform size	107 (2718)
	19	Turning radius, minimum outside	40/27.5 (1016/698)
	20	Stacking aisle, zero clearance w/48" W x 96" L pallet	149.3 (3793)
	21	Intersecting aisle, equal aisles w/48" W x 96" L pallet	163.2 (4145)
	22	Stability, comply with ANSI	113.3 (2878)
	23	Travel speed ¹ NL/RL	YES
	24	Lift speed NL/RL	6.5/6.5 (10.5/10.5)
	25	Lower speed NL / RL	ft/min
	26	Truck weight NL	See performance chart
	WT.	27	Axle loading - drive NL/RL
28		Axle loading - load wheels NL/RL	Without battery
29		Tire size, drive	lb (kg)
30		Tire size, load wheel	7050 (3198)
31		Wheelbase	6493/5476 (2945/2484)
32		Ground clearance	2557/6574 (1160/2982)
33		Ground clearance	in (mm)
34		Brakes, method of control	13.5/5.5 (343/140)
35		Brakes, method of operation	6.0/3.0 (152/76)
36		Battery	139.4 (3540)
ELECTRIC		37	Volts
	38	Minimum weight	40/27.5 (1016/698)
	39	Traction motor control method	149.3 (3793)
	40	Pump motor control method	163.2 (4145)
	41	Number of travel speeds	113.3 (2878)

Right angle stack and equal intersecting aisle dimensions provided with a 40" wide x 48" long pallet load, allowing zero clearance.

¹ Speeds are the same in either direction, with or without rated load. Steer angle <10 degrees.

² Optional with Hyster Power Collect™

CERTIFICATION: These Hyster® lift trucks meet the design and construction requirements of B56.1-1969, per OSHA Section 1910.178(a)(2), and also comply with the B56.1 revision in effect at time of manufacture. Performance specifications are for a truck equipped as described under standard equipment on this technical guide. Performance specifications are affected by the condition of the vehicle and how it is equipped, as well as by the nature, condition of the operating area, proper service and maintenance of the vehicle. If these specifications are critical, the proposed application should be discussed with your dealer.

BATTERY SPECIFICATIONS							
Number of cells	Cell size	Plates per cell	Capacity 6 hr rate amp hr (kwh)	Battery dimensions			Weight lb (kg)
				"X" (Width) in (mm)	"Y" (Length) in (mm)	"Z" (Height) in (mm)	
12	125	17	1000 (23.4)	38.1 (969)	13.5 (342)	30.6 (776)	1818 (825)
12	140	17	1120 (26.2)	38.1 (969)	13.5 (342)	30.6 (776)	1851 (840)
12	155	17	1240 (29.0)	38.1 (969)	13.5 (342)	30.6 (776)	1860 (844)
18	125	11	625 (21.9)	38.1 (967)	13.3 (339)	30.6 (776)	1800 (816)
18	140	11	700 (24.6)	38.1 (967)	13.3 (339)	30.6 (776)	1849 (839)
18	155	11	775 (27.2)	38.1 (967)	13.3 (339)	30.6 (776)	1859 (843)

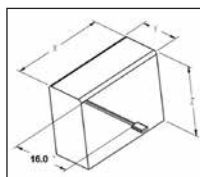

TRAVEL SPEEDS (24V & 36V)		
Fork height in (mm)	Steer angle <10° mph (kph)	Steer angle >10° mph (kph)
0 (0)	6.5 (10.5)	6.5 (10.5)
24 (610)	6.5 (10.5)	3.0 (4.8)
60 (1524)	6.0 (9.7)	2.7 (4.4)
116 (2946)	4.7 (7.5)	2.3 (3.6)
150 (3810)	3.9 (6.2)	2.0 (3.2)
195 (4953)	2.8 (4.5)	1.6 (2.6)
250 (6350)	1.5 (2.4)	1.2 (1.9)
272 (6909)	1.0 (1.6)	1.0 (1.6)
>272 (6909)	No travel*	No travel*

Note: Speed limits are for trucks at operating temperature with fully charged battery. Speeds are the same in either direction, with or without rated load.

For lift heights between 24.0" (610 mm) and 272.0" (6909 mm), traction speed is reduced when steering angle exceeds 10°.

* Travel above 272.0" (6909 mm) fork height requires a high level traction option. Capacity reduction required.

Battery compartment length is measured from front to rear. Battery compartment width is measured across truck. SB350 amp "red" connector, cable position B, Cable length 16" (405 mm). Maximum cable gauge 1/0 AWG battery with lid will NOT fit in battery compartment. Battery weight range 1500 - 2000 lb Amp hour capacity min/max - 24-volt truck 960/1240. 36 volt truck 600 / 775.

Contact your local dealer for additional information.

R30XMF3 FEATURES AND OPTIONS

PERFORMANCE	STD	OPT
24-volt AC electrical system	x	
AC transistor control	x	
AC traction motor	x	
DC controlled hydraulics	x	
On demand electric power steering	x	
AC steer motor	x	
Auto Deceleration System (ADS) with regenerative braking	x	
Ergonomically advanced multi-function control handle with rotational adjustment and single speed lift/lower	x	
4 operator selectable, programmable performance modes	x	
Smart-glide continuous height sensing	x	
36 volt AC electrical system		x
AC transistorized hydraulic control		x
6.25Khz wire guidance		x
5.25Khz wire guidance		x
Side guide rollers	x	
Lift limit with or without push button override	x	
Lowering limit with push button override		x
High level traction above 272" with restricted steer		x
DRIVE	STD	OPT
13 x 5.5 molded NDIIthane (non marking)	x	
6.0" x 3.0" articulating tandem - high load compound load wheel	x	
13.5 x 5.5 superior XL-AC (901 compound)		x
13.5 x 5.5 polyurethane (601 compound)		x
13.5 x 5.35 polyurethane – X grooved (601 compound)		x
Steer wheel angle graphic indication	x	
LIFT	STD	OPT
240" MFH/107" OALH 3-stage anti-rattle mast	x	
Lift limit with or without push button override	x	
Lowering limit with push button override	x	
HANDLING	STD	OPT
78.0" x 2.00" x 5.0" standard taper pin type forks	x	
84.0" x 2.00" x 5.0" standard taper pin type forks		x
Heavy duty pallet clamp - automatically engaged/foot released	x	
Heavy duty automatic pallet clamp with opening range from 1/2" to 6"		x
ERGONOMICS	STD	OPT
Shock dampening operator's compartment floor mat	x	
Non-adjustable vertical console	x	
6" vertical adjustable operator console		x
2 speed upper body fan - console mounted		x
OPERATION	STD	OPT
Battery connector SB-350 red	x	
40.0" wide x 27.5" deep operator platform	x	
39.0" L x 14.6" W x 31.5" H battery compartment	x	
175 amp red, position b-16" lead length battery connector	x	
42" inside dimension (open end clearance) 51.5" outside dimension (base width) outriggers	x	
Key switch start	x	
Multi-turn steering	x	
Electric park brake - automatically engaged/foot released	x	
Single hydraulic pump and motor	x	
Controller Area Network (CANbus) Communications	x	
Graphic LCD multi-function smart display with back lighting	x	
Hour meters; truck, traction and hoist pump	x	
Bar graphic battery discharge indicator	x	
Low battery lift interrupt	x	
Performance mode selection and indication	x	
LED status indicators with symbols	x	
User passwords and operator logs with history	x	

OPERATION (CONTINUED)	STD	OPT
Truck inspection check list	x	
Truck speed indication in MPH or KPH	x	
Slack chain indication	x	
Battery power disconnect button	x	
Operator convenience station with storage areas, trash bin, beverage & clipboard holders	x	
Full body harness and operator tether	x	
Battery compartment corrosive resistant steel rollers	x	
Retractable platform side gates with cushioning and lift/traction cutout interlock	x	
Electric horn	x	
Static discharge strap	x	
Battery stand	x	
Battery puller	x	
44" inside dimension (open end clearance) 53.5" outside dimension (base width)		x
46" inside dimension (open end clearance) 55.5" outside dimension (base width)		x
48" inside dimension (open end clearance) 57.5" outside dimension (base width)		x
27.5" deep x 48" wide		x
27.5" deep x 54" wide		x
27.5" deep x 60" wide		x
Safety glass shield		x
Fixed hoop side rails		x
Stability casters		x
Line driver		x
Keyless - toggle switch		x
Retractable operator tether with full body harness or medium body belt		x
Audible alarms self adjusting 82-102 db(A)		
- Back-up alarm - reverse direction activation		x
- Motion alarm - forward and reverse direction activation		x
- Motion alarm - continuous operation with key-on		x
DC to DC converter - 25 amps/300 watts @12 volts		x
Smart steer		x
30" tether boom extension		x
Outrigger cross tie		x
Battery connector SB-350 gray		x
Hyster Reaction™		x
SUPPLEMENTAL	STD	OPT
Operating manual and labels – English	x	
12 month/unlimited hours full truck warranty	x	
3 years/6,000 hour powertrain warranty	x	
Lifetime frame warranty	x	
Parts manual - printed or CD		x
5 year 10,000 hour part A comprehensive parts and labor warranty		x
5 year 10,000 hour part B powertrain parts and labor no deduct warranty		x
APPEARANCE	STD	OPT
2-part poly Hyster yellow paint	x	
CONSTRUCTION	STD	OPT
Standard application/environmental construction	x	
UL classification type "E"	x	
VISIBILITY	STD	OPT
Cantilever style overhead guard	x	
Wire mesh screen operator guard	x	
Amber LED strobe - continuous operation with key-on	x	
- Dome light and 2 speed fan package mounted on top of overhead guard		x
- Dome light, 2 speed fan and halogen glass lens spot light package		x
- Dome light, 2 speed fan and LED plastic lens spot light package		x
- 2 LED plastic lens spot lights mounted under overhead guard		x
ENERGY SYSTEM	STD	OPT
Lead acid	x	
Hyster Power Collect™		x



Hyster Company
P.O. Box 7006
Greenville, North Carolina
27835-7006

© Hyster Company. 2024, all rights reserved. Hyster and are trademarks of Hyster-Yale Group, Inc. Hyster products are subject to change without notice. Trucks may be shown with optional equipment.