

# SC1.2 SERIES

---



## COMPACT PEDESTRIAN HIGH LIFT STACKER PRODUCT TECHNICAL GUIDE



# TRUCK DIMENSIONS

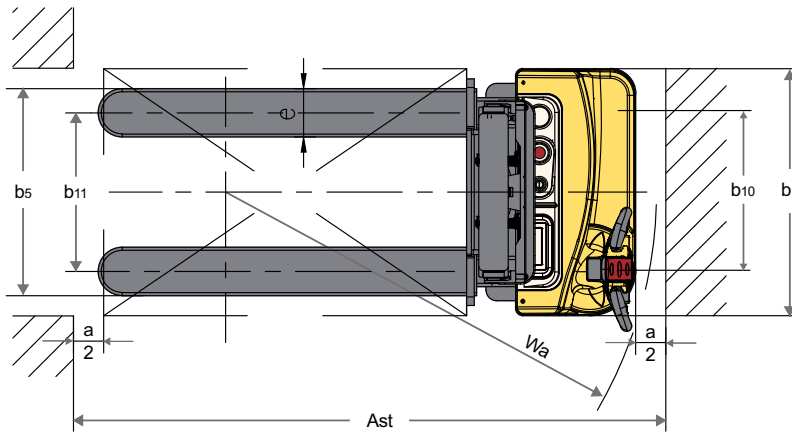
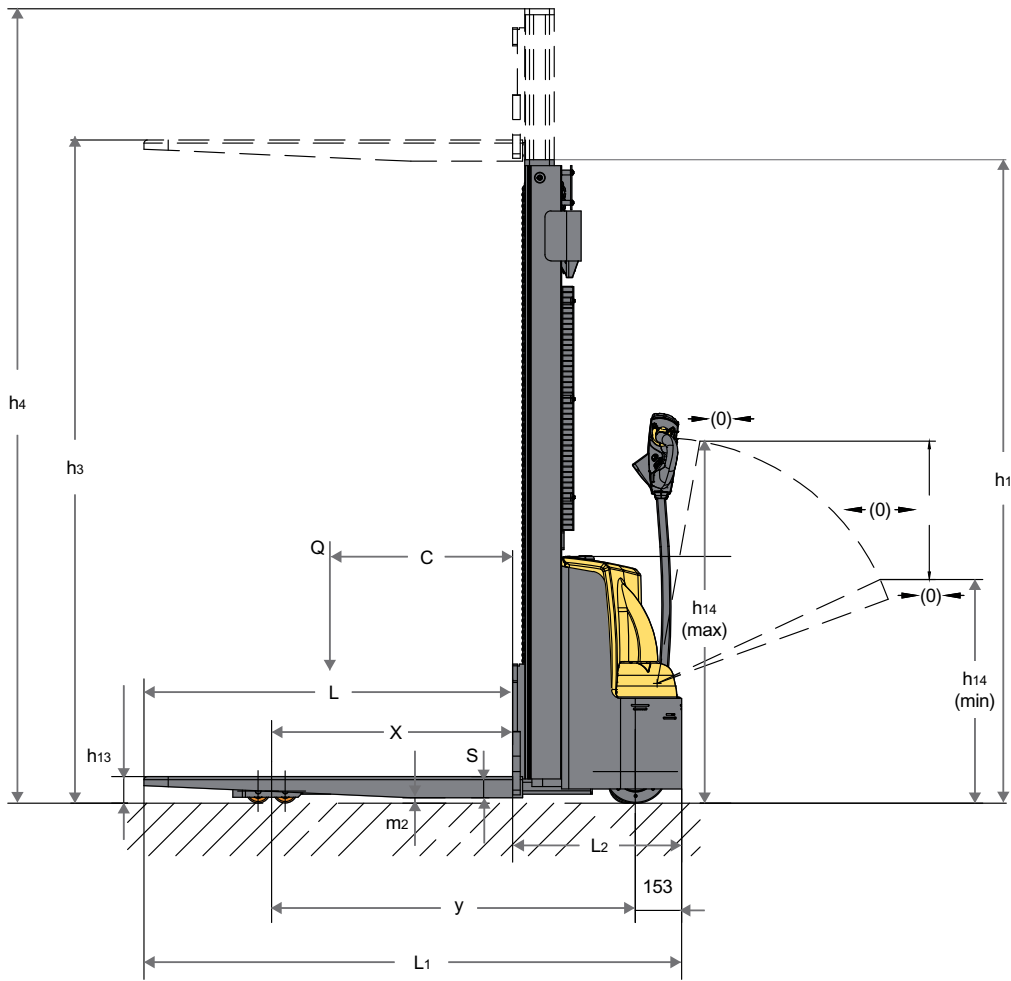

Mast Type	Height, Mast Lowered	Lift Height	Extended Mast height
	$h_1$ mm	$h_3$ mm	$h_4$ mm
2 Stage NFL	1730	2500	2935
	1980	3000	3435
	2230	3500	3935

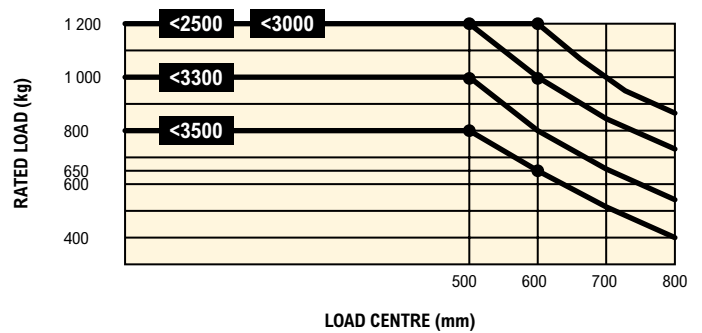

# SC1.2 SERIES SPECIFICATIONS

GENERAL	1-1	Manufacturer			Hyster		
	1-2	Model			SC1.2		
	1-3	Drive			Electric		
	1-4	Operator type			Pedestrian		
	1-5	Load capacity/rated load	Q	kg	1200		
	1-6	Load centre distance	c	mm	600		
	1-8	Load distance, centre of drive axle to fork	x	mm	800		
	1-9	Wheelbase	y	mm	1210		
	WEIGHT	2-1	Service weight (without battery) (560/680)		kg	529.4 / 502.4	556.4 / 523.4
2-1-1		Service weight (with 60Ah Li-battery) (560/680)		kg	543	570	589
2-2		Axle loading, laden front/rear (2.5m lifting height)		kg	526 / 1228.4		
2-3		Axle loading, unladen front/rear (2.5m lifting height)		kg	416 / 138.4		
WHEELS	3-1	Wheels			Polyurethane		
	3-2	Wheel size, front	∅ x width	mm	210 x 70		
	3-3	Wheel size, rear	∅ x width	mm	80 x 70		
	3-4	Additional wheels (dimensions)	∅ x width	mm	115 x 55		
	3-5	Wheels, number front/rear (x = driven wheels)			1 x + 1 / 4		
	3-6	Tread, front	b10	mm	550		
	3-7	Tread, rear	b11	mm	390 (560 fork width) / 525 (680 fork width)		
DIMENSIONS	4-2	Lowered mast height	h1	mm	1730	1980	2230
	4-4	Lift height	h3	mm	2500	3000	3500
	4-5	Extended mast height	h4	mm	2935	3435	3935
	4-9	Height of tiller in driving position, min./max.	h14	mm	910 / 1270		
	4-15	Height, lowered	h13	mm	85		
	4-19	Overall length	l1	mm	1730 (1150 fork length)		
	4-20	Length to face of forks	l2	mm	560		
	4-21-1	Overall width across chassis	b1	mm	820		
	4-21-2	Overall width across all/Outer width straddle	b2	mm	820		
	4-21-5	Inner width straddle	b14	mm	/		
	4-22	Fork dimensions	s/e/l	mm	70 x 160 x 1150		
	4-25	Width over forks	b5	mm	560 / 680		
	4-32	Ground clearance, centre of wheelbase	m2	mm	30		
	4-34-1	Aisle width for pallets 1000 x 1200 crossways	Ast	mm	2268	2268	2268
	4-34-2	Aisle width for pallets 800 x 1200 lengthways	Ast	mm	2194	2194	2194
	4-35	Turning radius	Wa	mm	1425		
	PERFORMANCE	5-1	Travel speed, with/without load		km/h	4 / 4.5	
5-2		Lift speed laden / unladen		mm/s	102 / 190		
5-3		Lowering speed laden / unladen		mm/s	30-135 / 20-200		
5-8		Max. gradeability, with/without load		%	5 / 10		
5-10		Service brake			Electromagnetic		
ELECTRIC ENGINE	6-1	Drive motor rating S2 60 min		kW	0.75		
	6-2	Lift motor rating at S3 15%		kW	2.5		
	6-4	Battery voltage/nominal capacity K5		V/Ah	24V / 60Ah Li-battery x 1		
	6-5	Battery weight +/- 5%		kg	14 (60Ah Li-battery)		
	6-6	Energy consumption according to EN 16796		kWh	0.42		
	8-1	Type of drive control			DC speed control		
8-4	Sound level at the driver's ear according to EN 12053			dB(A)	75		

## NOTES:

Specifications are affected by the condition of the vehicle and how it is equipped, as well as the nature and condition of the operating area. Inform your dealer of the nature and condition of the intended operating area when purchasing your Hyster® truck.

## NOTICE:

Care must be exercised when handling elevated loads. Operators must be trained and must read, understand and follow the instructions contained in the Operating Manual.

All values are nominal values and they are subject to tolerances. For further information, please contact the manufacturer.

Hyster products are subject to change without notice.

Lift trucks illustrated may feature optional equipment. Values may vary with alternative configurations.

 **Safety:** This truck conforms to the current EU requirements.



**HYSTER EUROPE**  
Centennial House, Building 4.5, Frimley Business Park,  
Frimley, Surrey, GU16 7SG, United Kingdom

Visit us online at [www.hyster.com](http://www.hyster.com) or call us at **+44 (0) 1276 538500**.

HYSTER-YALE UK LIMITED trading as Hyster Europe.

Registered Address: Centennial House, Building 4.5, Frimley Business Park, Frimley, Surrey GU16 7SG, United Kingdom.

Registered in England and Wales. Company Registration Number: 02636775.

©2024 Hyster-Yale Materials Handling, Inc. all rights reserved. Hyster and  are trademarks of Hyster-Yale Materials Handling, Inc.

Hyster products are subject to change without notice. Trucks may be shown with optional equipment.



Safety: This truck conforms to the current EU requirements